

starex[®]

ABS, ABS Alloy, ASA

ENJOY OUR EXCELLENCE AND EXPERTISE

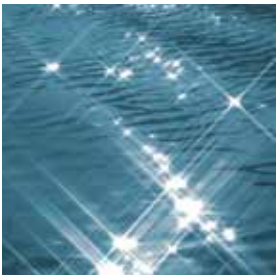

Contents

starex® Brand Identity 03

Product Portfolio 04

Product 05

Product Selection Guide 16

Applications 28

Total Solution Platform 36

Global Network 37



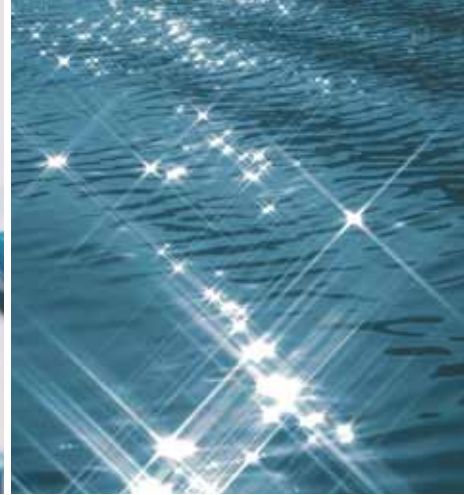

starex®

starex® is the Styrene product brand of Samsung Cheil Industries, representing the company's efforts to put together customer-centered technologies and know-how.

starex® covers the Styrene product groups such as ABS, ASA, EPS, SAN, while offering high-functionality choices through various lineups.

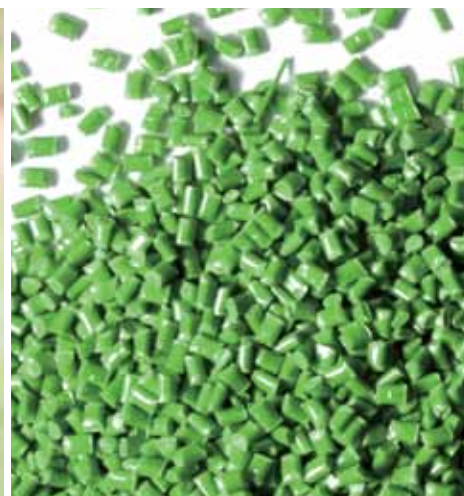

Product Portfolio

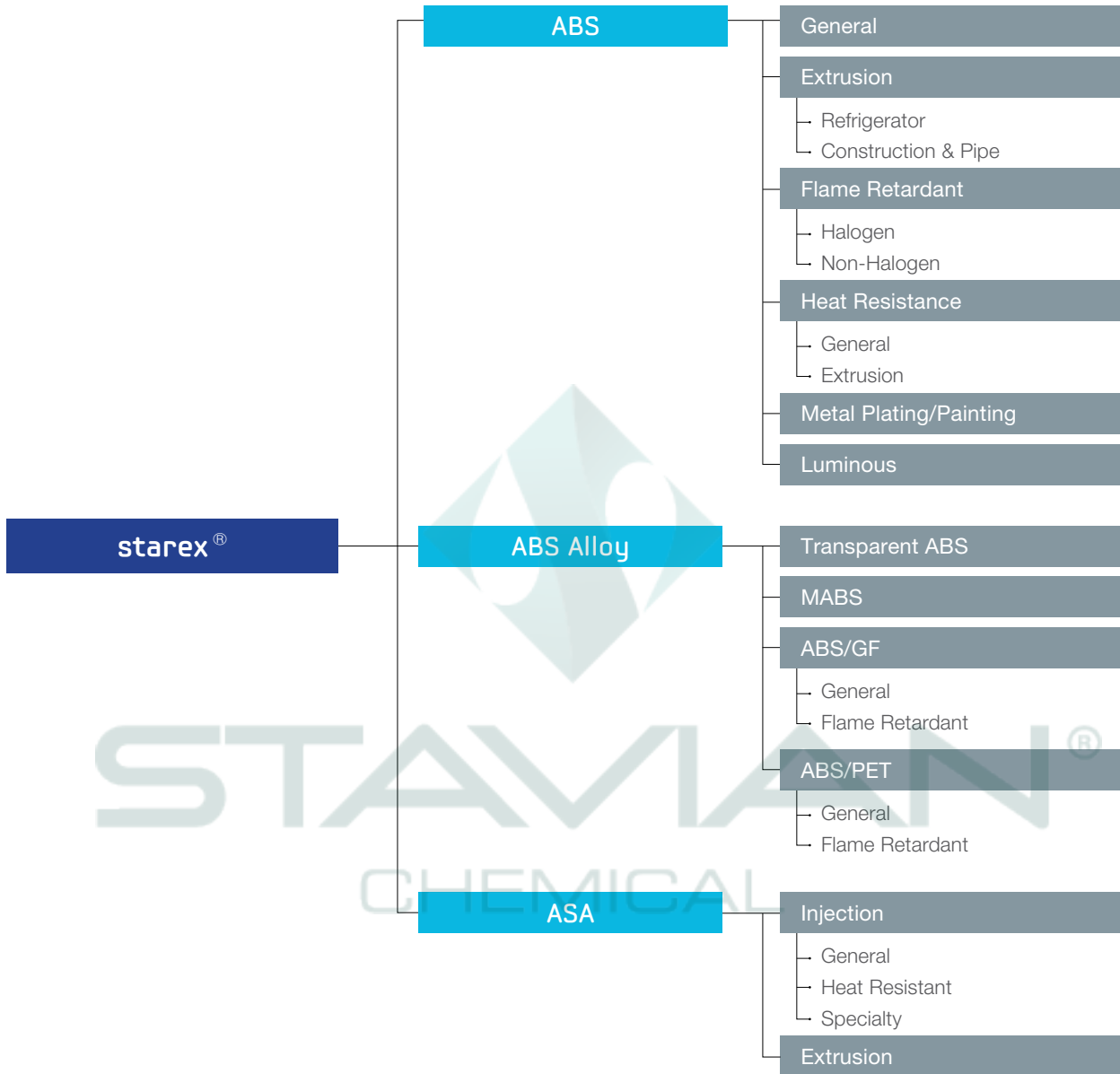

starex® ABS

starex® ABS is a practical material and that has great workability, high impact, and high modulus characteristics, as well as excellent colorability and gloss. starex® ABS maintains superb resistance to impact across a wide range of temperatures, as well as tensile strength, rigidity, and heat resistance.

starex® ABS Alloy

starex® ABS Alloy is an advanced high performance resin such as extreme transparent ABS, non-painting resin Luminous, eco-friendly PCM based materials and ABS/GF. Samsung Cheil Industries has differentiated product portfolio of ABS resin.

starex® ASA

starex® ASA is a high weatherable resin having superior chemical stability, while maintaining excellent glossiness, moldability, and mechanical properties of ABS resin. The starex® ASA is suitable for exterior materials because it does not discolor under UV exposure over a long time and its physical properties do not change much.

starex® General Purpose ABS

starex® ABS, composed of AN, BD and SM, has excellent impact strength, chemical resistance and dimensional stability, and is applicable to various products such as electrical and electronic devices, stationery and toys.



KEY FEATURES

- Excellent balance of properties
- High gloss, excellent heat stability
- Good processability suitable for various applications

APPLICATIONS

- TV
- Home appliance
- Toy
- Stationery
- Automotive

PRODUCT LINE-UP

GENERAL	HIGH FLOW	HIGH GLOSS	FUNCTIONAL
<ul style="list-style-type: none"> General <ul style="list-style-type: none"> SD-0150 <ul style="list-style-type: none"> SD-0150GP SD-0150UF SD-0150AT SD-0150 W CM-0140UV High Impact Strength <ul style="list-style-type: none"> SD-0170 SD-0170 W Ultra High Impact Strength <ul style="list-style-type: none"> SD-0190H High Modulus for <ul style="list-style-type: none"> BC-0130 X Chemical Resistant <ul style="list-style-type: none"> EG-0763 	<ul style="list-style-type: none"> General <ul style="list-style-type: none"> HF-0660I <ul style="list-style-type: none"> HF-0660IW High Flow <ul style="list-style-type: none"> HF-0680 Ultra High Flow <ul style="list-style-type: none"> HF-0690 M 	<ul style="list-style-type: none"> High Gloss <ul style="list-style-type: none"> HG-0760 <ul style="list-style-type: none"> HG-0760TV HG-0760GP Ultra High Gloss <ul style="list-style-type: none"> HP-0500 SG-0167 	<ul style="list-style-type: none"> Anti-Static <ul style="list-style-type: none"> AS-0151BS <ul style="list-style-type: none"> EA-0640 Anti-Bacterial <ul style="list-style-type: none"> NA-0660I Low Gloss <ul style="list-style-type: none"> SL-0100

starex® Extrusion ABS

starex® Extrusion ABS is most suitable for refrigerator liners and construction components. The plastic has good sheet extrusion stability, chemical resistance and vacuum moldability. starex® extrusion ABS for refrigerators especially is the world-class product with the biggest global market share.



KEY FEATURES

- Easy vacuum molding
- Outstanding impact strength and tensile strength
- Excellent chemical resistance & crack resistance

APPLICATIONS

- Refrigerator
- Construction & Pipe

PRODUCT LINE-UP

REFRIGERATOR INNER LINER	CONSTRUCTION MATERIAL	PIPE
<ul style="list-style-type: none"> CP <ul style="list-style-type: none"> General <ul style="list-style-type: none"> SV-0157 Thin wall <ul style="list-style-type: none"> QU-0191 S High Impact at low temp <ul style="list-style-type: none"> ST-0185 141B <ul style="list-style-type: none"> ES-0173 	<ul style="list-style-type: none"> General <ul style="list-style-type: none"> SV-0167 UV Resistance <ul style="list-style-type: none"> SV-0165 U SH-0160 	<ul style="list-style-type: none"> High Impact <ul style="list-style-type: none"> SP-0170 High Pressure <ul style="list-style-type: none"> SP-0180 SP-0183

starex[®] Flame Retardant ABS

In addition to the typical features of general purpose ABS mentioned above, starex[®] Flame Retardant ABS is specially formulated to have the self-extinguishability making it much safer for the use in the electrical & electronic applications complying with the UL 94 regulations, the most widely accepted fire safety standards.

starex[®] Flame Retardant ABS is take its lead in the global market thanks to its excellent balance of mechanical properties and processability.



KEY FEATURES

- High heat stability and good processability
- Excellent colorability
- Well Balanced physical properties

APPLICATIONS

- TV
- Monitor
- OA machine
- Wiring device

PRODUCT LINE-UP

NON-HALOGEN

- └ V-2
 - └ General
 - └ NH-0825
 - └ NH-0925 S
 - └ Heat Resistant
 - └ NH-0927

Br

- └ TBBA
 - └ 1.5T V-0
 - └ VH-0800
 - └ 2.0T V-0
 - └ VH-0815
 - └ 2.5T V-0, 3.0T 5VB
 - └ VH-0819 (High Flow)
 - └ 2.5T V-0
 - └ VH-0810

BEO

- └ BEO
 - └ 1.5T V-0, 2T 5VB
 - └ VE-0856
 - └ 1.5T V-0, 2.5T 5VB
 - └ VE-0860 P
 - └ VE-0860EX
 - └ 1.5T V-0
 - └ VE-0812
 - └ 2.0T V-0
 - └ VE-0852 (Chemical Resistance)
 - └ 2.0T V-0, 2.5T 5VB, 3.0T 5VA
 - └ VE-0855YS
 - └ 2.1T V-0, 2.5T 5VA
 - └ VE-0858

starex[®] Heat Resistant ABS

Although general purpose ABS has mechanical properties good enough for the practical use in terms of processability, impact strength, etc, its use is sometimes limited at high temperature due to the deformation of its molded products by heat. starex[®] High Heat Resistant ABS offers an attractive alternative to general purpose ABS and other engineering plastics making it suitable for the applications designed for the use at high temperature.



KEY FEATURES

- Low TVOC
- Chemical resistance
- High heat resistance & high flow

APPLICATIONS

- Automotive interior: Cockpit module parts, Power window, Switch panel, Pull handle, Console

PRODUCT LINE-UP

EXTRUSION

- └ Blow Molding
 - └ BM-0320 J
 - └ SR-0320BM

INJECTION

- └ General
 - └ SR-0300 (VST 102)
- └ Semi Heat Resistant (Under VST 105)
 - └ SR-0310
 - └ SR-0315 V
 - └ SR-0310FM
- └ Heat Resistant (VST 106~110)
 - └ SR-0320 K
 - └ HR-0370F
- └ Super Heat Resistant (Over VST 111)
 - └ SR-0325LT (Low TVOC)
 - └ SR-0330M
 - └ SR-0340M

starex[®]

Metal Plating/Painting ABS

In general, ABS is a suitable material for metal plating. In consideration of better productivity, however, the material should be more easily etched and have better adhesion strength. starex[®] Metal Plating ABS generates uniform anchor holes during the etching process and has excellent adhesion strength making it possible to achieve higher productivity and lower metal plating rejections.



KEY FEATURES

Metal Plating ABS

- High adhesion strength
- Excellent appearance
- Chemical resistance & dimensional stability

Painting ABS

- Chemical resistance
- Painting uniformity
- Excellent painting appearance

APPLICATIONS

Metal Plating ABS

- Automotive exterior: Radiator grille, Rear garnish, Emblem, Outside mirror, Door handle
- TV: Stand base

Painting ABS

- Bike

PRODUCT LINE-UP

METAL PLATING/PAINTING

- Metal Plating
 - MP-0160 R (General)
 - MP-0670 (Good Appearance)
- Painting
 - PT-0170 M (Chemical Resistance)
 - PT-0180 (General)

starex[®] Transparent ABS (TRANEX)

starex[®] Transparent ABS is deliberately formulated to have an excellent balance of transparency, mechanical properties, and processability, making it suitable for the applications such as electrical and electronic parts, OA machines, and toys that need both transparency and good mechanical properties.



KEY FEATURES

- Super clear transparency
- Excellent color consistency and stability
- Well-balanced properties

APPLICATIONS

- Washing machine: Top cover
- Vacuum cleaner: Dust box
- TV frame
- Miscellaneous: Toy, Dispenser, Food containers

PRODUCT LINE-UP

GENERAL

└ TX-0510T

HIGH IMPACT

└ TX-0520T
└ TX-0530T

starex[®] Scratch Resistant MABS

starex[®] MABS(ABS/PMMA) has excellent processability and high impact strength as well as scratch resistance and excellent coloring property originated from PMMA. starex[®] MABS offers deep color effect without painting. Its superior surface quality makes it suitable for the exterior parts of electrical and electronic devices.

Samsung Cheil Industries is taking the lead in the scratch-resistance materials market for TV housing.



KEY FEATURES

- Pencil scratch resistant: H or higher
- Excellent surface gloss
- No need to coat: Cost reduction, environment-friendly
- Good chemical resistance to especially IPA and ethanol

APPLICATIONS

- TV
- Monitor
- Home theater

STAVIAN[®]
CHEMICAL

PRODUCT LINE-UP

2H	H	F	HB
<ul style="list-style-type: none"> General <ul style="list-style-type: none"> BF-0679P Transparency <ul style="list-style-type: none"> TF-0930 	<ul style="list-style-type: none"> General <ul style="list-style-type: none"> BF-0950 BF-0677HF Transparency <ul style="list-style-type: none"> BF-0677 	<ul style="list-style-type: none"> General <ul style="list-style-type: none"> BF-0670F Transparency <ul style="list-style-type: none"> BF-0670T 	<ul style="list-style-type: none"> General <ul style="list-style-type: none"> BF-0370 Transparency <ul style="list-style-type: none"> BF-0675HW

starex[®] High Impact Strength ABS/GF

starex[®] ABS/GF, glass fiber reinforced ABS, features excellent flexural modulus, heat resistance, and dimensional stability. starex[®] ABS/GF is applicable to frames and precision parts that require high flexural modulus and dimensional stability.

KEY FEATURES

- High impact strength and heat resistance
- Low changes in the mechanical property over a wide temperature range
- Dimensional stability

APPLICATIONS

- TV
- Monitor
- Air conditioner fan
- OA



PRODUCT LINE-UP

GENERAL

- GF5%
 - └ GR-4005
- GF10%
 - └ GR-4010
- GF15%
 - └ GR-4015A
- GF20%
 - └ GR-4020
- GF30%
 - └ GR-4030

FLAME RETARDANT

- GF10%
 - └ VG-4910
- GF20%
 - └ VG-4920
 - └ VG-4920F

starex[®] Weather Resistant ASA (WEATHEX)

starex[®] WEATHEX is Samsung Cheil Industries' new weather resistant ASA. WX series has both superior weatherability and impact resistance. It also has outstanding color fastness and gloss retention, as well as dimensional stability. Thus it can be used for various outdoor applications such as automotive, construction materials, ships, and leisure products.



KEY FEATURES

- Excellent weatherability
- Superior impact strength
- Color fastness and gloss retention

APPLICATIONS

- Automotive: Outside mirror, Rear lamp housing, Radiator grille
- Building & Construction: Window profile, Roofing, Rain gutter, Fencing
- Home appliance
- Sports & Leisure

PRODUCT LINE-UP

INJECTION

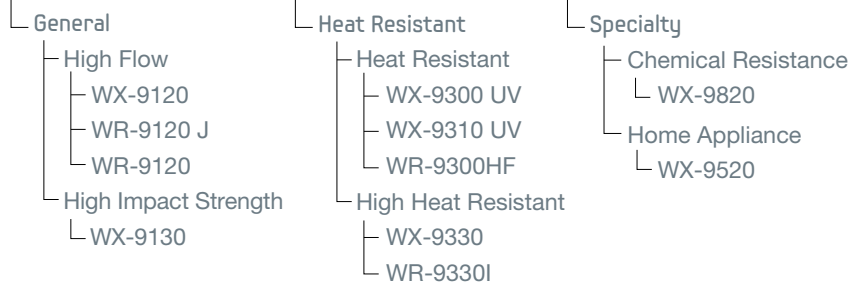

EXTRUSION

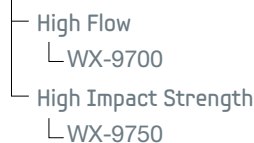

starex[®] Luminous

Luminous is a metallic-look resin that offers the appearance of painted surface without painting process, making it possible to reduce the manufacturing cost considerably by removing the time-consuming and costly painting process and also making the process environmentally friendly by removing the use of solvents.



KEY FEATURES

- Fine exterior: Metallic-look without painting
- Eco-friendly process: Cost reduction through process simplification, Recyclability (No painting), Eco-friendly manufacturing process (No solvent use)
- A wide range of various visual effects are available

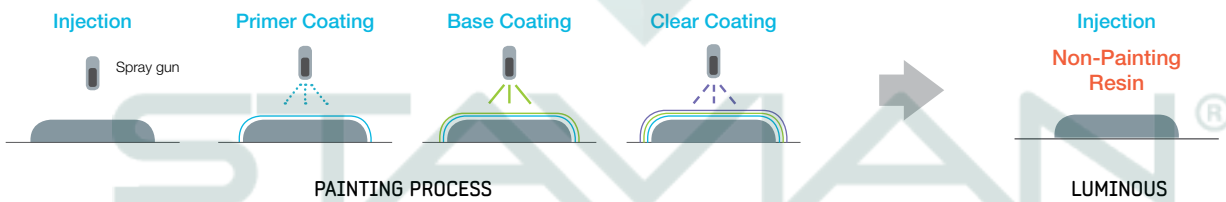

APPLICATIONS

- Refrigerator: Home bar, Dispenser, Door cap
- Vacuum cleaner: Dust cover, Cover control, Hand grip
- Washing machine: Top cover, LID, Control panel, Detergent drawer panel

PRODUCT LINE-UP

LUMINOUS S	LUMINOUS P	LUMINOUS M	LUMINOUS XM
<ul style="list-style-type: none"> ABS <ul style="list-style-type: none"> LX-0760 LX-0971 LX-0970 L 	<ul style="list-style-type: none"> ABS <ul style="list-style-type: none"> LX-0951 LX-0957 LX-0957EX 	<ul style="list-style-type: none"> ABS <ul style="list-style-type: none"> LX-0981 LX-0987EX 	<ul style="list-style-type: none"> LM-0990

starex[®] PCM based ABS/PET

Recycling PET bottles, Samsung Cheil Industries has developed PCM-based (Post-Consumer Materials) environmentally friendly material applicable to automotive parts, exteriors of monitor and OA machines, etc. It is designed to better help comply with the environment regulations such as EPEAT in the United States. Recycling 1MT of PET bottles is known to save as many as 427 fir trees.



KEY FEATURES

- Easier to comply with eco-certifications (EPEAT Gold & TCO Edge)
- Reduction of CO₂ emission
- Chemical resistance & well-balanced properties

APPLICATIONS

- Monitor
- Mobile phone

PRODUCT LINE-UP

GENERAL

- Chemical Resistant
 - └ EG-7000
- Eco-Friendly
 - └ PCM 15%
 - └ GC-0703
 - └ PCM 28%
 - └ GC-0700
 - └ PCM 35%
 - └ GC-0710
 - └ PCM 70%
 - └ GC-0750

FLAME RETARDANT

- Eco-Friendly
 - └ GC-0920

starex[®] General Purpose ABS

General ABS													
Properties	Test Method	Condition	Unit	SD-0150	SD-0150GP	SD-0150UF	SD-0150AT	SD-0150 W	CM-0140UV	SD-0170	SD-0170 W	SD-0190H	
PHYSICAL PROPERTIES													
Specific Gravity	ASTM D792	Natural Color	g/cm ³	1.04	1.04	1.04	1.04	1.04	1.04	1.03	1.04	1.03	
Melt Flow Index	ASTM D1238	220°C, 10kg	g/10min			11	19			11.5		9.8	
		200°C, 5kg	g/10min	2.5	2.2			2.2	3		1.4		
	ISO 1133	220°C, 10kg	g/10min			11	20			11.5		9.8	
		200°C, 5kg	g/10min	2.5	2.2			2.2	3		1.4		
Mold Shrinkage	ASTM D955		%	0.3-0.6	0.3-0.6	0.3-0.6	0.3-0.6	0.3-0.6	0.3-0.6	0.4-0.7	0.4-0.7	0.4-0.7	
MECHANICAL PROPERTIES													
Tensile Strength at Yield	ASTM D638	5mm/min	kgf/cm ²	420	360	400	400	410	430	320	340	350	
	ISO 527-1A	50mm/min	Mpa	51	45	48	40	42	45	40	34	38	
Tensile Strain at Break	ASTM D638	5mm/min	%			16							
		50mm/min	%	11	14	9.5				12		18	
Flexural Strength	ASTM D790	2.8mm/min	kgf/cm ²	630	590	600	530	630	640	520	500	480	
	ISO 178	2mm/min	Mpa	76	72	68	69	63	65	62	50	59	
Flexural Modulus	ASTM D790	2.8mm/min	kgf-cm ²	21,000	21,000	20,000	20,000	22,000	21,000	17,000	17,000	17,000	
	ISO 178	2mm/min	Mpa	2,500	2,400	2,200	2,350	2,200	2,000	2,000	1,700	1,900	
Izod Impact Strength	ASTM D256	(notched) 1/4	kgf-cm/cm	20	28	29	33	18	20	35	33	40	
		(notched) 1/8	kgf-cm/cm			36							
Charpy Impact Strength	ISO 179 1eA	(notched)	KJ/m ²	17	26	32	33	19	20	30	30	44	
Izod Impact Strength	ISO 180 1A	(notched)	KJ/m ²	17	25	30	30		20	29		42	
Rockwell Hardness	ASTM D785	R-Scale		109	105	103	106	110	109	95	95	95	
	ISO 2039-2	R-Scale		113	108	102	104	110	109	101	95	95	
THERMAL PROPERTIES													
Heat Deflection Temperature	ASTM D648	18.5kgf/cm ²	°C	84		84	85		76				
	ISO 75-2	1.8MPa	°C	79	79	79				78		78	
VICAT Softening Temperature	ISO R306	B/50	°C	98	97	96	97	99	95	94	93	94	
FLAME CHARACTERISTICS													
Flammability	UL94	-	-	HB	HB	HB	HB	HB	HB	HB	HB	HB	HB

General ABS		High Flow ABS				High Gloss ABS				Functional			
BC-0130 X	EG-0763	HF-0660I	HF-0660IW	HF-0680	HF-0690 M	HG-0760	HG-0760GP	HP-0500	SG-0167	AS-0151BS	EA-0640	NA-0660I	SL-0100
1.05	1.04	1.04	1.04	1.04	1.1	1.08	1.04	1.05	1.05	1.04	1.05	1.04	1.03
	12							20	5.5				7.5
2.6		3.3	3.5	5.5	8.9	3.3	3.8			3.5	1.8	3.2	
	12							20					7.5
		3.3	3.5	5.5	8.9	3.3	3.8			3.5		3.2	
0.3-0.6	0.3-0.6	0.3-0.6	0.3-0.6	0.3-0.6	0.3-0.6	0.3-0.6	0.3-0.6	0.3-0.6	0.3-0.6	0.3-0.6	0.3-0.6	0.3-0.6	0.4-0.7
490	380	400	400	420	400	400	400	520	510	410	510	390	
	36	45	47	46	43	48	45	59		45		44	35
					20			39				30	
		13	18	19	25	19	21	11		19		15	74
720	550	600	600	630	640	610	600	810	780	600	750	590	450
	50	72	76	74	68	77	72	88		74		71	57
22,000	20,000	22,000	22,000	21,000	24,000	21,000	20,000	26,000	24,000	22,000	26,000	21,000	16,000
	2,000	2,300	2,500	2,600	2,300	2,600	2,400	2,800		2,600		2,300	1,800
10	26	20	20	20	13	21	23	13	7.5	21	20	22	6
					15			13	9			35	7
		21	20	19	17	20	20	12		20		23	11
		20	20	18	18	20	20	12		20		22	12
113	100	109	112	107	109	113	108	116	115	109	96	107	97
	100	111	112	111	109	113	110	117		110		106	93
86		84	85	82	84		91			83		82	
		74	75	78	73	76	76	82		76		79	77
99	95	92	95	97	93	96	94	103	103	95	95	99	97
HB	HB	HB	HB	HB	HB	HB	HB	HB	HB	HB	HB	HB	HB

starex[®] Extrusion ABS

Extrusion ABS													
Properties	Test Method	Condition	Unit	SV-0157	ST-0185	QU-0191 S	ES-0173	SV-0167	SV-0165 U	SH-0160	SP-0170	SP-0180	SP-0183
PHYSICAL PROPERTIES													
Specific Gravity	ASTM D792	Natural Color	g/cm ³	1.04	1.08	1.08	1.05	1.03	1.08	1.04	1.03	1.04	1.04
Water Absorption	ASTM D570		%										
Melt Flow Index	ASTM D1238	220°C, 10kg	g/10min	5.2	4.3	4.3	2.6	5.4	8.8	8	7.1	6	3.5
		200°C, 5kg	g/10min										
	ISO 1133	220°C, 10kg	g/10min		4.3	4.3	2.6	5.4	8.8	8	7.1	6	
		200°C, 5kg	g/10min										
Mold Shrinkage	ASTM D955		%	0.4-0.6	0.4-0.6	0.4-0.6	0.4-0.6	0.4-0.6		0.4-0.6	0.4-0.6		
MECHANICAL PROPERTIES													
Tensile Strength at Yield	ASTM D638	5mm/min	kgf/cm ²	410	470	490	400	400	400	410	390	370	420
	ISO 527-1A	5mm/min	Mpa							42			
		50mm/min	Mpa		49	52	41	44	51		43	45	
Tensile Strain at Break	ASTM D638	5mm/min	%		35	80	60	50		80	50		50
Flexural Strength	ASTM D790	2.8mm/min	kgf/cm ²	550	580	720	530	570		560	540	550	620
	ISO 178	2mm/min	Mpa		76	82	64	67	81		63	65	
		5mm/min	Mpa							58			
Flexural Modulus	ASTM D790	2.8mm/min	kgf/cm ²	20,000	21,500	24,500	19,000	20,000		19,000	17,500	19,000	19,000
	ISO 178	2mm/min	Mpa		2,500	2,700	2,000	2,200	2,800		2,000	2,100	
		5mm/min	Mpa							80			
Izod Impact Strength	ASTM D256	(notched) 1/4	kgf-cm/cm	26	30	24	36	37	22	33	39	38	41
		(notched) 1/8	kgf-cm/cm			27	45	44		45	48		
Charpy Impact Strength	ISO 179 1eA	(notched)	KJ/m ²		35	27	42	36	17		39	38	
Izod Impact Strength	ISO 180 1A	(notched)	KJ/m ²		35	26	44	33	21	45	36	36	
Rockwell Hardness	ASTM D785	R-Scale											
	ISO 2039-2	R-Scale											
THERMAL PROPERTIES													
Heat Deflection Temperature	ASTM D648	18.56kgf/cm ²	°C		91	91	89	89		90	88		91
	ISO 75-2	1.8MPa	°C		85	82	80	78	81		77	77	
VICAT Softening Temperature	ISO R306	B/50	°C	101	100	101	97	97	100	99	97	97	101
FLAME CHARACTERISTICS													
Flammability	UL94	-	-	HB	HB	HB	HB	HB	HB	HB	HB	HB	HB

starex[®] Flame Retardant ABS

Flame Retardant ABS										
Properties	Test Method	Condition	Unit	NH-0825	NH-0925 S	NH-0927	VE-0856	VE-0860 P	VE-0860EX	VE-0812
PHYSICAL PROPERTIES										
Specific Gravity	ASTM D792	Natural Color	g/cm ³	1.05	1.05	1.05	1.15	1.18	1.17	1.17
Melt Flow Index	ASTM D1238	220°C, 10kg	g/10min					13.4	17	
		200°C, 5kg	g/10min	8.2	6.5	3.5	3.5			3.5
	ISO 1133	220°C, 10kg	g/10min					13.4	17	
		200°C, 5kg	g/10min	8.2						
Mold Shrinkage	ASTM D955		%	0.3-0.6	0.3-0.6	0.3-0.6	0.3-0.6	0.3-0.6	0.3-0.6	0.3-0.6
MECHANICAL PROPERTIES										
Tensile Strength at Yield	ASTM D638	5mm/min	kgf/cm ²		420	550	400	430	420	380
		50mm/min	kgf/cm ²	420						
	ISO 527-1A	5mm/min	Mpa							
		50mm/min	Mpa	46				45	47	
Tensile Strain at Break	ASTM D638	5mm/min	%		25	25				
		50mm/min	%							
Flexural Strength	ASTM D790	2.8mm/min	kgf/cm ²	660	640	670	580	620	560	570
	ISO 178	2mm/min	Mpa	71				73	72	
Flexural Modulus	ASTM D790	2.8mm/min	kgf/cm ²	22,000	23,000	26,000	20,000	22,000	21,000	21,000
	ISO 178	2mm/min	Mpa	2,500				2,300	2,300	
Izod Impact Strength	ASTM D256	(notched) 1/4	kgf-cm/cm				17	13	20	15
		(notched) 1/8	kgf-cm/cm	22	21	18				
Charpy Impact Strength	ISO 179 1eA	(notched)	KJ/m ²	23				22	23	
Izod Impact Strength	ISO 180 1A	(notched)	KJ/m ²	20				25	25	
Rockwell Hardness	ASTM D785	R-Scale		105	105	110	95	105	98	97
	ISO 2039-2	R-Scale		110				105	104	
THERMAL PROPERTIES										
Heat Deflection Temperature	ASTM D648	18.56kgf/cm ²	°C	78	83	88	80	90	83	81
	ISO 75-2	1.8MPa	°C	71				80	78	
VICAT Softening Temperature	ISO R306	B/50	°C	88	93	99	90	99	94	91
FLAME CHARACTERISTICS										
Flammability	UL94	HB	mm							
		V-2	mm	0.75, 1.5, 2.5, 3.0	0.75, 1.5, 2.5, 3.0	1.0, 3.0		1.5, 2.5-2.7		
		V-1	mm							
		V-0	mm				1.5, 2.0, 2.5, 3.0	2	1.5, 2.5-2.7	1.5, 2.5, 3.0
		5VA	mm					3		
		5VB	mm					2.0, 2.5	2.5-2.7	2.5-2.7

starex[®] Flame Retardant ABS

Flame Retardant ABS										
Properties	Test Method	Condition	Unit	VE-0852	VE-0855YS	VE-0858	VH-0800	VH-0810	VH-0815	VH-0819
PHYSICAL PROPERTIES										
Specific Gravity	ASTM D792	Natural Color	g/cm ³	1.2	1.2	1.18	1.17	1.16	1.15	1.16
Melt Flow Index	ASTM D1238	220°C, 10kg	g/10min							
		200°C, 5kg	g/10min	1.6	6	3.2	5.4	6	3.8	8
	ISO 1133	220°C, 10kg	g/10min							
		200°C, 5kg	g/10min	1.6	6	3.2	5.4	5.7	4.2	8
Mold Shrinkage	ASTM D955		%	0.3-0.6	0.2-0.6	0.3-0.6				0.3-0.6
MECHANICAL PROPERTIES										
Tensile Strength at Yield	ASTM D638	5mm/min	kgf/cm ²	340	300	360	420	400	400	380
		50mm/min	kgf/cm ²							
	ISO 527-1A	5mm/min	Mpa		35					
		50mm/min	Mpa	44		41	46	45	45	42
Tensile Strain at Break	ASTM D638	5mm/min	%	56		12				18
		50mm/min	%							
Flexural Strength	ASTM D790	2.8mm/min	kgf/cm ²	490	480	540	620	610	600	610
	ISO 178	2mm/min	Mpa	65	54	60	75	71	71	67
Flexural Modulus	ASTM D790	2.8mm/min	kgf/cm ²	16,000	16,000	18,000	22,000	22,000	22,000	22,000
	ISO 178	2mm/min	Mpa	2,100	2,000	2,000	2,700	2,500	2,400	2,300
Izod Impact Strength	ASTM D256	(notched) 1/4	kgf-cm/cm	29	13	20	20	23	25	20
		(notched) 1/8	kgf-cm/cm	45		26				21
Charpy Impact Strength	ISO 179 1eA	(notched)	KJ/m ²	33	13	30	20	25	22	25
Izod Impact Strength	ISO 180 1A	(notched)	KJ/m ²	32	13	27	21	23	19	22
Rockwell Hardness	ASTM D785	R-Scale		79	90	93	107	103	100	103
	ISO 2039-2	R-Scale		77	90	94	107	106	104	105
THERMAL PROPERTIES										
Heat Deflection Temperature	ASTM D648	18.56kgf/cm ²	°C	83		80				76
	ISO 75-2	1.8MPa	°C	75		74	71	70	71	70
VICAT Softening Temperature	ISO R306	B/50	°C	87	87	90	86	85	86	85
FLAME CHARACTERISTICS										
Flammability	UL94	HB	mm							
		V-2	mm							
		V-1	mm						1.5	
		V-0	mm	2		2.1, 2.5, 3.0	1.5, 3.0, 6.0	2.5, 3.0, 6.0	2	2.1-2.3, 3.0
		5VA	mm			2.5, 3.0				
		5VB	mm			2.5			2	3

starex[®] Heat Resistant ABS

Heat Resistant ABS													
Properties	Test Method	Condition	Unit	BM-0320 J	SR-0320BM	SR-0300	SR-0310	SR-0310FM	SR-0315 V	SR-0320 K	HR-0370F	SR-0330M	SR-0340M
PHYSICAL PROPERTIES													
Specific Gravity	ASTM D792	Natural Color	g/cm ³	1.04	1.04	1.05	1.04	1.04	1.04	1.05	1.06	1.06	1.07
Water Absorption	ASTM D570		%	0.3				0.3		0.3	0.05		0.05
Melt Flow Index	ASTM D1238	220°C, 10kg	g/10min	4	3.5	13.4	13	18	26	9.4		2.9	2.5
		200°C, 5kg	g/10min								0.9		
	ISO 1133	220°C, 10kg	g/10min	4	3.5	13	13	18	26	9.4		2.9	2.5
		200°C, 5kg	g/10min								0.9		
Mold Shrinkage	ASTM D955		%	0.5	0.6			0.5		0.5	0.6		
MECHANICAL PROPERTIES													
Tensile Strength at Yield	ASTM D638	5mm/min	kgf/cm ²		430	450	410	400	400	420	470	390	430
		50mm/min	kgf/cm ²	430									
	ISO 527-1A	50mm/min	Mpa	42	43	48	48	46	42	50	49	45	47
Tensile Strain at Break	ASTM D638	5mm/min	%					35	41	35	14	27	14
		50mm/min	%	25									
Flexural Strength	ASTM D790	2.8mm/min	kgf/cm ²	590	640	620	630	640	640	650	700	600	640
	ISO 178	2mm/min	Mpa	67	73	76	77	75	73	81	78	74	79
Flexural Modulus	ASTM D790	2.8mm/min	kgf/cm ²	19,700	20,000	23,000	21,000	21,000	22,000	22,000	22,000	20,000	22,000
	ISO 178	2mm/min	Mpa	2,200	2,300	2,600	2,500	2,600	2,500	2,700	2,500	2,200	2,400
Izod Impact Strength	ASTM D256	(notched) 1/4	kgf-cm/cm	25	18	23	18	18	21	19	15	15	14
		(notched) 1/8	kgf-cm/cm			30	20		25		16	17	16
Charpy Impact Strength	ISO 179 1eA	(notched)	KJ/m ²	25	21	23	16	16	24	16	16	17	12
Izod Impact Strength	ISO 180 1A	(notched)	KJ/m ²	26	22	24	17	18	24	17	18	17	12
Rockwell Hardness	ASTM D785	R-Scale		104	107	112	110	109	109	113	110	109	110
	ISO 2039-2	R-Scale		107	106	112	111	112	108	113	110	111	112
THERMAL PROPERTIES													
Heat Deflection Temperature	ASTM D648	18.56kgf/cm ²	°C	93	94	88	93	90	90	94	95	102	102
	ISO 75-2	1.8MPa	°C	83	89	81	82	83	80	86	86	94	99
VICAT Softening Temperature	ISO R306	B/50	°C	104	108	102	104	104	102	106	106	116	119
FLAME CHARACTERISTICS													
Flammability	UL94	-	-	HB	HB	HB	HB	HB	HB	HB	HB	HB	HB

starex[®] Luminous

Luminous (Non-painting)											
Properties	Test Method	Condition	Unit	LX-0760	LX-0970 L	LX-0971	LX-0951	LX-0957	LX-0981	LX-0987EX	LM-0990
PHYSICAL PROPERTIES											
Specific Gravity	ASTM D792	Natural Color	g/cm ³	1.04	1.05	1.05	1.04	1.09	1.05	1.09	1.1
Water Absorption	ASTM D570		%				0.05				
Melt Flow Index	ASTM D1238	220°C, 10kg	g/10min		20	16	29	12	21	10	15
		200°C, 5kg	g/10min	3.9							
	ISO 1133	220°C, 10kg	g/10min				29				
		200°C, 5kg	g/10min	3.9							
Mold Shrinkage	ASTM D955		%							0.76	
MECHANICAL PROPERTIES											
Tensile Strength at Yield	ASTM D638	5mm/min	kgf/cm ²					460		440	
		50mm/min	kgf/cm ²	450	440	510	460		470		490
	ISO 527-1A	50mm/min	Mpa	45			50				50
Tensile Strain at Break	ASTM D638	50mm/min	%	21		13	14				20
Flexural Strength	ASTM D790	2.8mm/min	kgf/cm ²	640	700	710	690	700	660	670	610
	ISO 178	2mm/min	Mpa	72			79				70
Flexural Modulus	ASTM D790	2.8mm/min	kgf/cm ²	23,000	23,000	24,000	24,000	26,000	24,000	25,000	20,000
	ISO 178	2mm/min	Mpa	2,400			2,600				2,240
Izod Impact Strength	ASTM D256	(notched) 1/4	kgf-cm/cm	14	16	20	14	15	21	14	12
		(notched) 1/8	kgf-cm/cm	14	17	21	15	17	21	16	14
Charpy Impact Strength	ISO 179 1eA	(notched)	KJ/m ²	19			15				12
Izod Impact Strength	ISO 180 1A	(notched)	KJ/m ²	17			14				13
Rockwell Hardness	ASTM D785	R-Scale		109	108	110	108	111	106	110	107
	ISO 2039-2	R-Scale		109			111				112
THERMAL PROPERTIES											
Heat Deflection Temperature	ASTM D648	18.5kgf/cm ²	°C	85	89	88	85	85	84	86	81
	ISO 75-2	1.8MPa	°C	77			77				70
VICAT Softening Temperature	ISO R306	B/50	°C	97	98	98	96	95	96	96	88
FLAME CHARACTERISTICS											
Flammability	UL94	-	-	HB	HB	HB	HB	HB	HB	HB	HB

starex[®] Metal Plating/Painting ABS

Metal Plating/Painting							
Properties	Test Method	Condition	Unit	MP-0160 R	MP-0670	PT-0170 M	PT-0180
PHYSICAL PROPERTIES							
Specific Gravity	ASTM D792	Natural Color	g/cm ³	1.04	1.04	1.05	1.04
Water Absorption	ASTM D570		%		0.3		0.3
Melt Flow Index	ASTM D1238	220°C, 10kg	g/10min				
		200°C, 5kg	g/10min	1.5	2.3	1.4	3.7
	ISO 1133	220°C, 10kg	g/10min			18	
		200°C, 5kg	g/10min		2.3		3.7
Mold Shrinkage	ASTM D955		%		0.5	0.5-0.6	0.5
MECHANICAL PROPERTIES							
Tensile Strength at Yield	ASTM D638	5mm/min	kgf/cm ²	400	450	440	400
	ISO 527-1A	50mm/min	Mpa		51	39	46
Tensile Strain at Break	ASTM D638	5mm/min	%		25	14	55
Flexural Strength	ASTM D790	2.8mm/min	kgf/cm ²	560	660	610	640
	ISO 178	2mm/min	Mpa		72	80	71
Flexural Modulus	ASTM D790	2.8mm/min	kgf/cm ²	20,000	21,500	20,000	22,000
	ISO 178	2mm/min	Mpa		2,350	2,350	2,300
Izod Impact Strength	ASTM D256	(notched) 1/4	kgf·cm/cm	26	27	29	22
		(notched) 1/8	kgf·cm/cm		29	47	25
Charpy Impact Strength	ISO 179 1eA	(notched)	KJ/m ²		25	19	22
Izod Impact Strength	ISO 180 1A	(notched)	KJ/m ²		25	18	22
Rockwell Hardness	ASTM D785	R-Scale		102	106	111	108
	ISO 2039-2	R-Scale			106	111	109
THERMAL PROPERTIES							
Heat Deflection Temperature	ASTM D648	18.56kgf/cm ²	°C	86	88	88	86
	ISO 75-2	1.8MPa	°C		80	88	78
VICAT Softening Temperature	ISO R306	B/50	°C	96	100	97	98
FLAME CHARACTERISTICS							
Flammability	UL94	-	-	HB	HB	HB	HB

starex[®] ABS Alloy

ABS/GF												
Properties	Test Method	Condition	Unit	GR-4005	GR-4010	GR-4015A	GR-4020	GR-4030	VG-4910	VG-4920	VG-4920F	
PHYSICAL PROPERTIES												
Specific Gravity	ASTM D792	Natural Color	g/cm ³	1.08	1.15	1.19	1.18	1.27	1.12	1.33	1.33	
Melt Flow Index	ASTM D1238	220°C, 10kg	g/10min	15	7.8	7	5.6	5.4	23	25	42	
		250°C, 10kg	g/10min									
		250°C, 2.16kg	g/10min									
	ISO 1133	220°C, 10kg	g/10min		7.8	7	5.6	5.4				
		250°C, 10kg	g/10min									
		200°C, 5kg	g/10min									
Mold Shrinkage	ASTM D955		%	0.2-0.4	0.1-0.3		0.1-0.3	0.1-0.3	0.1-0.3	0.1-0.3	0.1-0.3	
MECHANICAL PROPERTIES												
Tensile Strength at Yield	ASTM D638	5mm/min	kgf/cm ²	600	740	740	900	1040	750	900	870	
		50mm/min	kgf/cm ²									
	ISO 527-1A	50mm/min	Mpa									
		5mm/min	Mpa	600	740	740	900	1040	750	900	870	
Tensile Strain at Break	ASTM D638	5mm/min	%		3.4		2.9	2.6				
Flexural Strength	ASTM D790	2.8mm/min	kgf/cm ²	890	1,000	1,000	1,300	1,300	800	1,050	1,050	
	ISO 178	2mm/min	Mpa		110	95	140	150				
Flexural Modulus	ASTM D790	2.8mm/min	kgf/cm ²	31,000	41,000	54,000	61,000	79,000	37,000	60,000	58,000	
	ISO 178	2mm/min	Mpa		4,100	5,000	6,100	8,300				
Izod Impact Strength	ASTM D256	(notched) 1/4	kgf-cm/cm		8.7		7	6.5				
		(notched) 1/8	kgf-cm/cm	8	9	7	7.5	7.3	7	5	6	
		(unnotched) 1/4	kgf-cm/cm									
		(unnotched) 1/8	kgf-cm/cm									
Charpy Impact Strength	ISO 179 1eA	(notched)	KJ/m ²		11	5	9.7	8.6				
Izod Impact Strength	ISO 180 1A	(notched)	KJ/m ²		10	6	9	10				
Rockwell Hardness	ASTM D785	R-Scale		110	114	110	112	112	109	110	110	
	ISO 2039-2	R-Scale			114	110	114	112				
Pencil Scratch	JIS K 5401	500g weight										
		1000g weight										
THERMAL PROPERTIES												
Heat Deflection Temperature	ASTM D648	18.56kgf/cm ²	°C	96	100	102	105	103	97	96	93	
	ISO 75-2	1.8MPa	°C		99		104	103				
VICAT Softening Temperature	ISO R306	B/50	°C		106	106	107	107				
FLAME CHARACTERISTICS												
Flammability	UL94	HB	mm	1.60-1.75	1.5, 3.0, 6.0	1.5-1.65	1.5, 3.0, 6.0	1.5, 3.0, 6.0				
		V-2	mm									
		V-1	mm									
		V-0	mm						1.6, 2.5, 3.0	1.6, 2.0, 3.0	1.6, 2.0, 3.0	
		5VA	mm						2.5	2.0, 3.0	2.0, 3.0	
		5VB	mm									
OTHER PROPERTIES												
Gloss	ASTM D523		%									
Yellow Index	ASTM D1925		%									
Transmissivity	ASTM D1003	3.2mm	%									
Haze	ASTM D1003	3.2mm	%									

Transparent ABS				MABS					
	TX-0510T	TX-0520T	TX-0530T	BF-0370	BF-0675HW	BF-0670F	BF-0670T	BF-0677HF	BF-0677F
	1.1	1.1	1.1	1.05	1.09	1.12	1.11	1.13	1.13
	17	15	13	18	12	19	23	19	14.5
	16	15	15	18			23	19	
				0.3-0.6		0.3-0.6	0.3-0.6	0.3-0.6	0.3-0.6
	460	440	420	520	400	510	510	480	500
	450	430	380	520	400	510	510	480	500
				25		25	18	15	24
	650	600		770	580	750	750	700	710
	70	70	62	87			74	80	
	21,000	20,000	19,500	25,000	17,000	24,000	24,000	25,000	23,900
	2,200	2,200	1,900	2,800			2,400	2,600	
				13				9	
	13	15	17	15	10.5	8.5	7.5	12	9
	13	12	15	14			8	10	
	10	12	16	12			7.4	10	
	109	106	101.6	112	102	114	115	114	116
	110	107	105	115			116	116	
					HB	F		H	H
				HB			F		
				89	78	82	80	84	81
	72	71	70	83			73	76	
	90	89	87	102	90	96	89	96	93
	1.5, 3.0	1.5, 3.0	1.5, 3.0	1.0, 1.5, 3.0	1.5, 3.0	1.5, 3.0	1.5, 3.0	1.5, 3.0	1.5, 3.0
	88	88							
	2.8	3							

starex[®] ABS Alloy

				MABS				ABS/PET			
Properties	Test Method	Condition	Unit	BF-0679P	BF-0950	TF-0930	EG-7000	GC-0700	GC-0703	GC-0710	GC-0750
PHYSICAL PROPERTIES											
Specific Gravity	ASTM D792	Natural Color	g/cm ³	1.13	1.11	1.1	1.1	1.09	1.07	1.12	1.11
Melt Flow Index	ASTM D1238	220°C, 10kg	g/10min	13	13	22					
		250°C, 10kg	g/10min				35				
		250°C, 2.16kg	g/10min								
	ISO 1133	220°C, 10kg	g/10min		13						
		250°C, 10kg	g/10min				35				
		200°C, 5kg	g/10min								
Mold Shrinkage	ASTM D955		%	0.3-0.6		0.4	0.4-0.7	0.4-0.7		0.4-0.7	
MECHANICAL PROPERTIES											
Tensile Strength at Yield	ASTM D638	5mm/min	kgf/cm ²	500	520	620					
		50mm/min	kgf/cm ²				390	410	400	410	500
	ISO 527-1A	50mm/min	Mpa				390	410	400	410	500
		5mm/min	Mpa	500	520	620					
Tensile Strain at Break	ASTM D638	5mm/min	%	18		12	40	40		40	
Flexural Strength	ASTM D790	2.8mm/min	kgf/cm ²	730	750	950	570	530	520	620	700
	ISO 178	2mm/min	Mpa		85	80	60	58	50	60	
Flexural Modulus	ASTM D790	2.8mm/min	kgf/cm ²	24,100	26,000	29,000	20,000	17,500	18,500	19,100	21,000
	ISO 178	2mm/min	Mpa		2,800	2,600	1,900	1,900	1,900	1,900	
Izod Impact Strength	ASTM D256	(notched) 1/4	kgf-cm/cm			2		20		12	
		(notched) 1/8	kgf-cm/cm	8	11	2	21	42	30	28	30
		(unnotched) 1/4	kgf-cm/cm			30					
		(unnotched) 1/8	kgf-cm/cm			30					
Charpy Impact Strength	ISO 179 1eA	(notched)	KJ/m ²		8	2	34	10		5.2	
Izod Impact Strength	ISO 180 1A	(notched)	KJ/m ²		7	2	27	8	30	5	
Rockwell Hardness	ASTM D785	R-Scale		116	116	118	95	96	100	96	106
	ISO 2039-2	R-Scale			116	118	101	97		100	
Pencil Scratch	JIS K 5401	500g weight		2H	H	2H					
		1000g weight									
THERMAL PROPERTIES											
Heat Deflection Temperature	ASTM D648	18.56kgf/cm ²	°C	85		84	78	80		80	80
	ISO 75-2	1.8MPa	°C			84	70	71		70	
VICAT Softening Temperature	ISO R306	B/50	°C	97	100	94	88	93	91	94	99
FLAME CHARACTERISTICS											
Flammability	UL94	HB	mm	1.5, 3.0	1.5~3.0	1.5~3.0	1.5, 3.0	3	1.5, 3.0	1.5, 3.0	3
		V-2	mm								
		V-1	mm								
		V-0	mm								
		5VA	mm								
		5VB	mm								
OTHER PROPERTIES											
Gloss	ASTM D523		%								
Yellow Index	ASTM D1925		%				20			25	
Transmissivity	ASTM D1003	3.2mm	%								
Haze	ASTM D1003	3.2mm	%								

starex[®] ASA

ASA													
Properties	Test Method	Condition	Unit	WX-9120	WR-9120 J	WR-9120	WX-9130	WX-9300UV	WX-9310UV	WR-9300HF	WR-9330I	WX-9700	WX-9750
PHYSICAL PROPERTIES													
Specific Gravity	ASTM D792	Natural Color	g/cm ³	1.06	1.07	1.06	1.06	1.07	1.09	1.07	1.07	1.07	1.07
Melt Flow Index	ASTM D1238	220°C, 10kg	g/10min	18	26	17.6	3	12	6	15	5	9	4
	ISO 1133	220°C, 10kg	g/10min	18		17.6	3	12	6.2	15	5		4
MECHANICAL PROPERTIES													
Tensile Strength at Yield	ASTM D638	5mm/min	kgf/cm ²	460	450	480		440	440	460	480	430	410
	ISO 527-1A	50mm/min	Mpa	43		46	45	49	49	50	52		43
Tensile Strain at Break	ISO 527-1A	5mm/min	%	18		18		13	12	16	11		
Flexural Strength	ASTM D790	2.8mm/min	kgf/cm ²	670	650	680	600	680	700	700	710	620	570
	ISO 178	2mm/min	Mpa	65		70	65	71	75	76	80	65	62
Flexural Modulus	ASTM D790	2.8mm/min	kgf/cm ²	22,000	21,000	22,000	19,000	22,000	22,000	23,000	23,000	20,000	18,000
	ISO 178	2mm/min	Mpa	2,000	2,300	2,000	2,300	2,300	2,300	2,500	2,600	2,030	1,950
Izod Impact Strength	ASTM D256	(notched) 1/8	kgf-cm/cm	24	21	20	50	20	18	12	14	50	53
Charpy Impact Strength	ISO 179 1eA	(notched)	KJ/m ²	14		10	14	12	16.4	8.6	10	15	32
Izod Impact Strength	ISO 180 1A	(notched)	KJ/m ²	14		8.3	12	10	16	9.3	9	10	
	ASTM D785	R-Scale		103	105	108	98	105	102	107	107	99	95
Rockwell Hardness	ISO 2039-2	R-Scale		103		108	98	106	106	111	108	96	95
THERMAL PROPERTIES													
Heat Deflection Temperature	ASTM D648	18.56kgf/cm ²	°C	89	87	83		89	92	88		77	
	ISO 75-2	1.8MPa	°C	74		77	77	79	82	80	82	75	77
VICAT Softening Temperature	ISO R306	B/50	°C	92	98	96	95	96	102	99	101	96	94

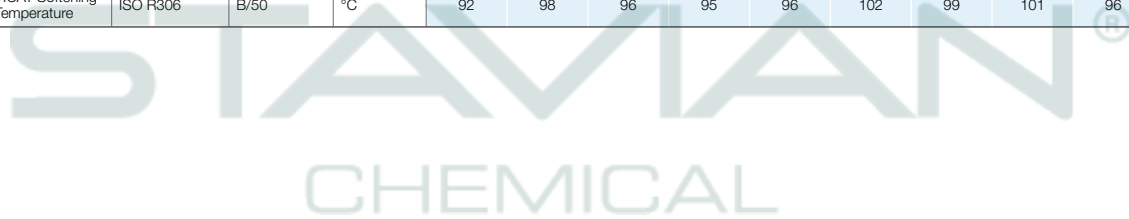

Refrigerator

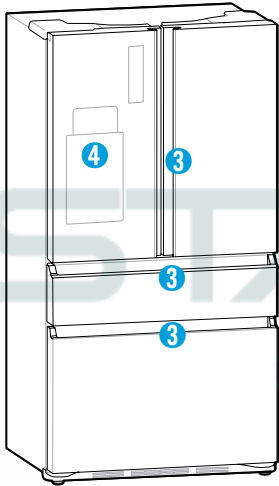
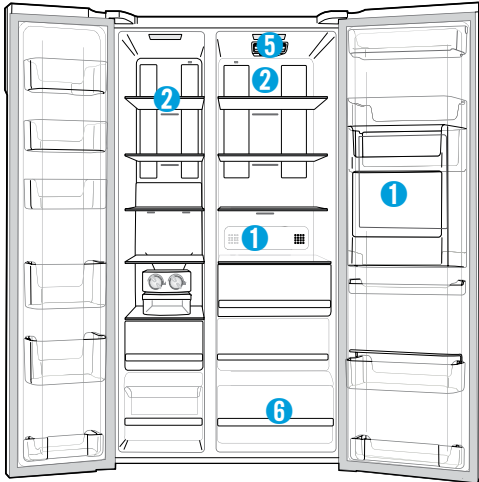

1. Liner Case
ABS QU-0191 S
ABS SV-0157



2. LED Cover
FR-PC FD-1112



3. Handle
ABS HG-0760GP
Luminous LX-0971



4. Case Dispenser
ABS HG-0760GP
Luminous LX-0971

5. Power Box
FR-ABS VE-0860 P
FR-HIPS VE-1801
PC/ABS NH-1015V

6. Vegetable box
ABS HG-0760GP

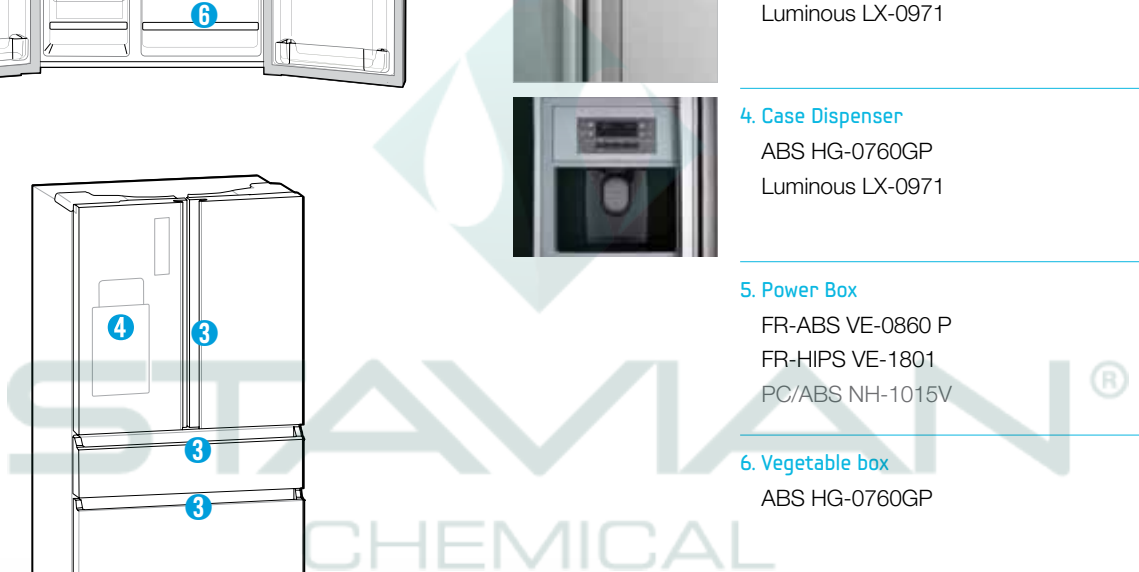

Washing Machine



1. Detergent Box

Chemical Resistant ABS EG-7000, EG-0763
ABS HG-0760GP



2. Drawer Cover

Luminous ABS LX-0971
ABS HG-0760GP



3. Control Panel

Luminous ABS LX-0970 M
ABS HG-0760GP
Transparent ABS TX-0510T

4. Control Box (Inner)

FR-ABS VE-0860 P
FR-HIPS VE-1801
PC/ABS NH-1015V



5. Diaphragm

TPE (Thermoplastic Elastomers)
EK-1045



6. Front Door Frame

Metal Plating ABS MP-0160 R
Luminous ABS LX-0971
ABS HG-0760GP, ASA WX-9520



7. Transparent Door Window

Transparent ABS TX-0520T



8. Top Cover Assembly

Luminous ABS LX-0971
Chemical Resistant ABS EG-7000, EG-0763
ABS SD-0150



9. Control Panel

Luminous ABS LX-0971
ABS HG-0760GP

Control Box (Inner)

FR-ABS VE-0860 P
FR-HIPS VE-1801
PC/ABS NH-1015V

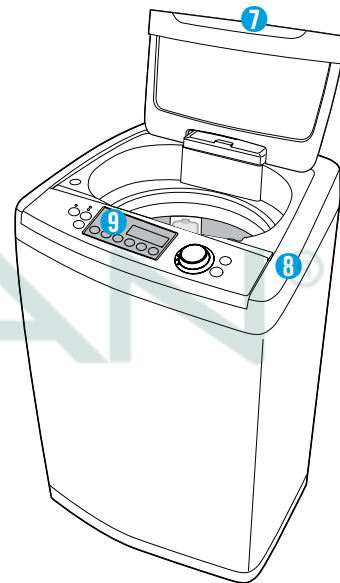
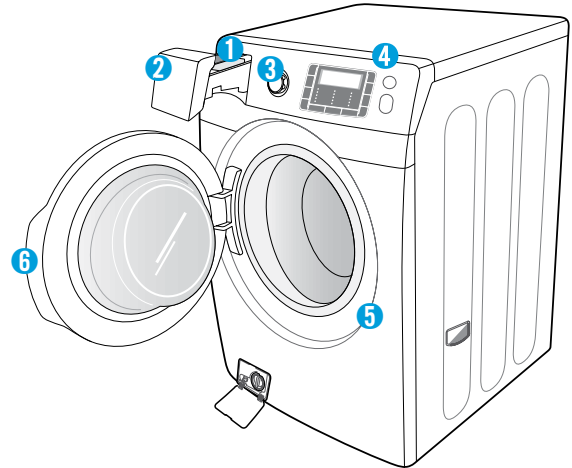

Vacuum Cleaner

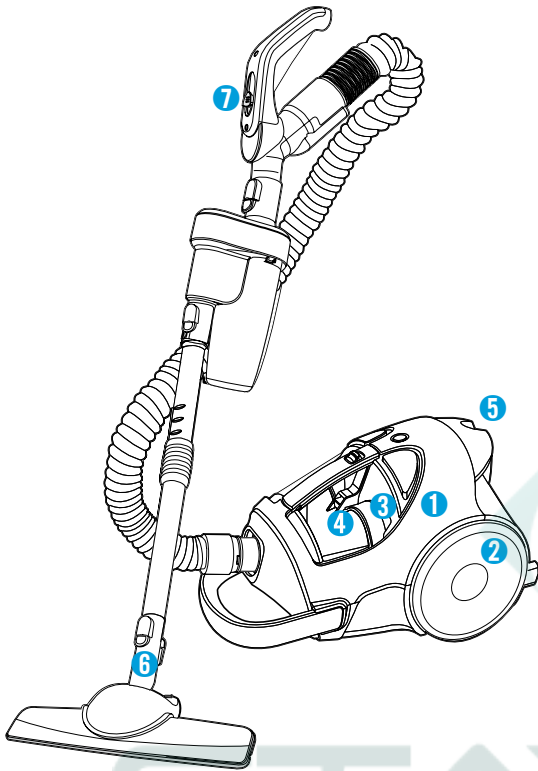

1. Body
ABS HG-0760GP
Luminous LX-0970 M, LX-0971



2. Wheel Cap
ABS HG-0760GP



3. Dust Cabinet
Transparent ABS TX-0510T, TX-0520T
PC SC-1220R



4. Case Cyclone
Transparent ABS TX-0510T



5. Gasket
TPE



6. Pipe Connector
ABS SD-0170



7. Handy Unit
ABS HG-0760GP
Transparent ABS TX-0510T, TX-0520T



Air Conditioner



1. Panel Door
ABS HF-0690 M



2. Panel Display
MABS TF-0930



3. Cabi Body
ABS HF-0690 M



4. Frame
Luminous LX-0970 M



5. Blade
ABS HG-0760GP
Luminous LX-0970 M



6. Propeller Fan
ABS/GF GR-4020

7. Case PCB, Cover PCB
FR-ABS VE-0860 P
FR-HIPS VE-1801
PC/ABS NH-1015V

8. Cross Fan
SAN/GF GR-5020 T

9. Drain Fan
ABS/PET EG-7030

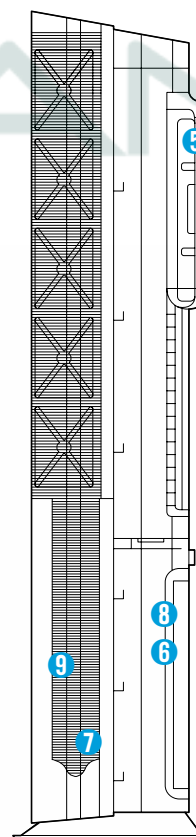
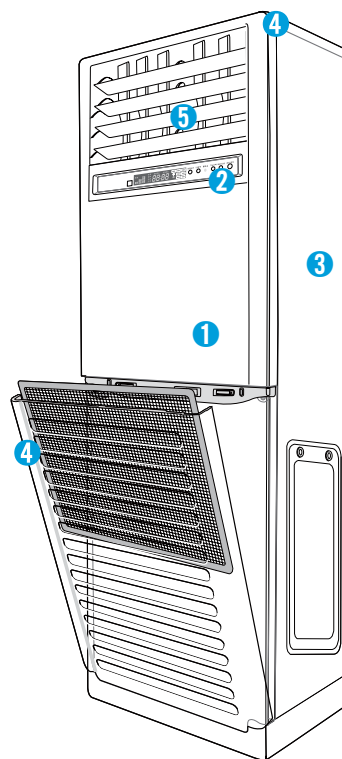

TV/Monitor

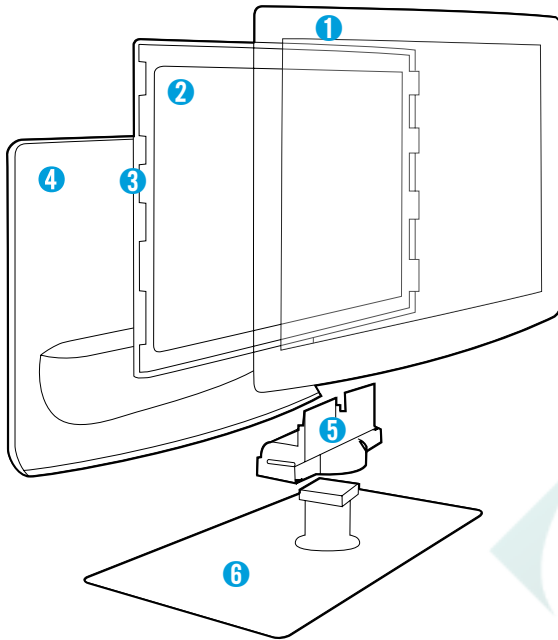

1. Front Cover

MABS BF-0950
 ABS HG-0760TV, SD-0150
 FR PC/ABS NH-1017D, NE-1030,
 NH-1017SG
 Transparent ABS TX-0510T

Double Injection

FR PC TN-1045
 FR PC/ABS NE-1010
 MABS TF-0930, SF-0505HW, BF-0950



2. Back Light Frame

PC/ABS/GF LS-1150G
 FR PC LH-1070W



3. Middle Cover

PC/ABS/GF 15% LS-1159

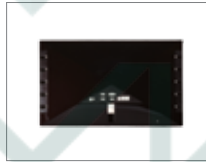

4. Rear Cover

mPPE NH-1904
 FR PS VE-1801, VE-1805



5. Guide Stand Neck

PC/GF 20% HF-3200 H
 FR PC/GF 20% HF-3201GP



6. Stand Base

MABS BF-0950
 ABS HG-0760TV, SD-0150
 FR PC/ABS NH-1017D, NH-1017SG
 Metal plating ABS MP-0670
 Metal plating PC/ABS QP-1010



OA – Multifunctional Copier



1. Internal

Developer & Toner :
 FR ABS/GF 20% VG-4920
 FR ABS VE-0812
 LSU: PC/GF 30% HM-3301GL
 PC/GF 20% HF-3200H
 Fuser : FR PBT/GF30% VB-5300GS
 FR PC/GF20% NH-3208GL
 Main frame(Chassis) :
 FR ABS VE-0860 P
 FR PC NH-1023P



2. ADF / Tray

Transparent PC(HB) SC-1220R
 Transparent ABS(HB)
 TX-0510, TX-0520
 ABS(HB) CM-0140



3. Exterior & Others

Housing

NH PC/ABS NE-1029, NH-1015V,
 GC-1017
 ABS(HB) CM-0140
 FR ABS VE-0812, VE-0856

Cassette

ABS(HB) CM-0140, GC-0700

Gear

PPS/GF 40% XP-2140

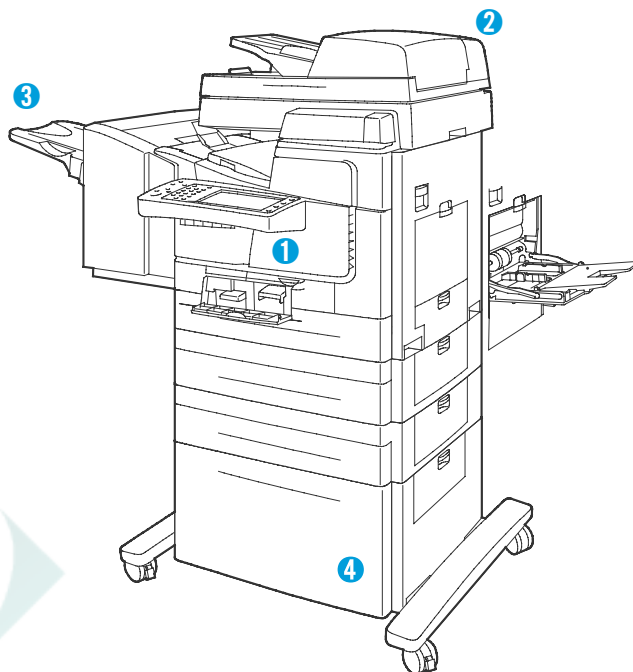

Automotive

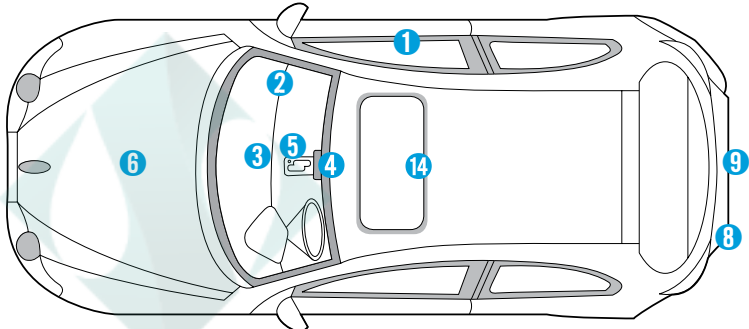
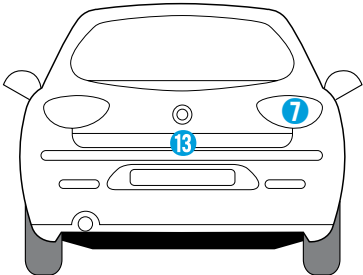
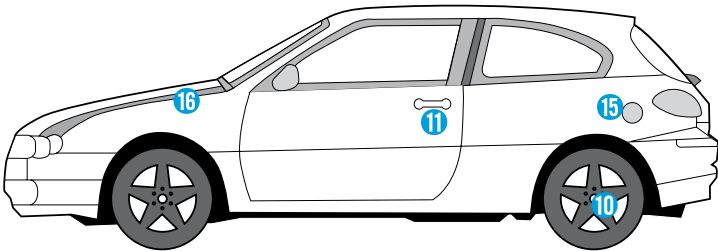
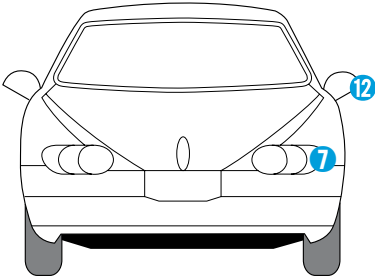

STAVMAN[®] CHEMICAL

INTERIOR



1. Power Window Switch Cover
Heat Resistance ABS
SR-0325 K, SR-0325LT



2. Air Vent
PC/PBT, PC/ABS



3. Center Fascia
PC, PC/ABS



4. Overhead Console
PC/ASA



5. Console
Heat Resistance ABS
SR-0325 K, SR-0325LT



UTH



6. Junction Box
PA/PPE



HEV Battery Housing
PA/GF



Eco Wire
PPE/Elastomer

STRUCTURE



14. Panorama Sunroof Frame
PBT/ASA/GF

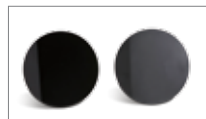

15. Fuel Filler Door
PA/PPE/CNT

16. Fender
PA/PPE/CNT

LIGHTING



7. Head Lamp Bexel
PBT/PET



Rear Lamp Housing
PC/ABS

EXTERIOR



8. Tailgate Garnish
PC/ABS,
Metal Plating ABS MP-0670



9. Rear Spoiler
Blow Molding ABS BM-0320 J



10. Wheel Cover
Metal Plating PC/ABS,
PC/ABS, PA/PPE



11. Outside Door Handle
Metal Plating PC/ABS



12. Side Mirror
ASA WX-9310UV, PBT/PET/GF



13. Radiator Grill
Metal Plating ABS MP-0670
ASA WX-9310UV



Total Solution Platform

INTEGRATED SOLUTIONS

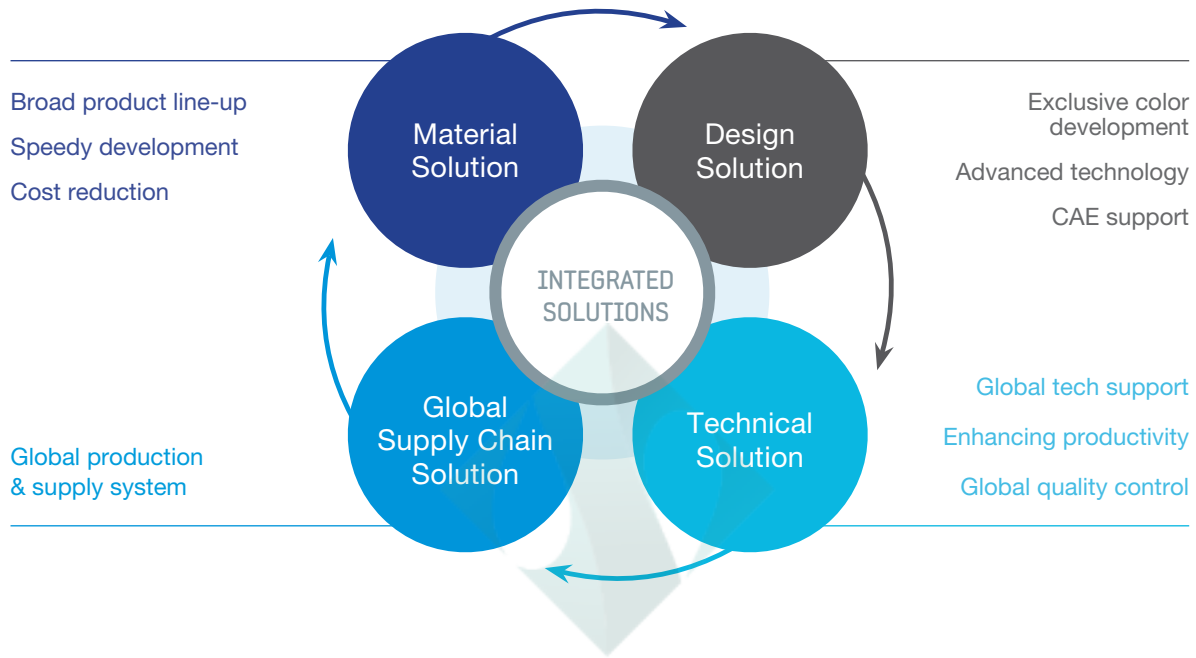

TOTAL SOLUTION PROVIDER

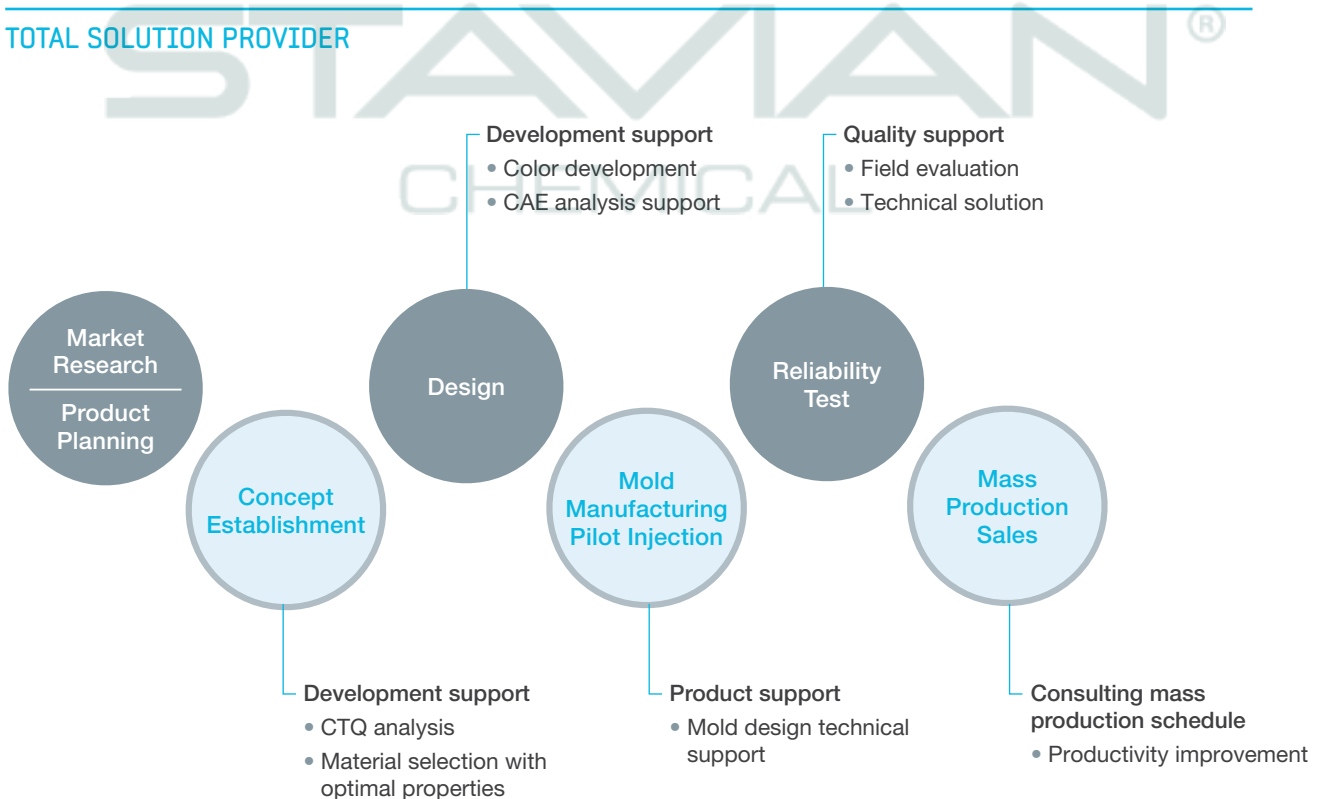

Global Network

- HEADQUARTERS
- GLOBAL SUBSIDIARY
- SALES OFFICE
- PLANT

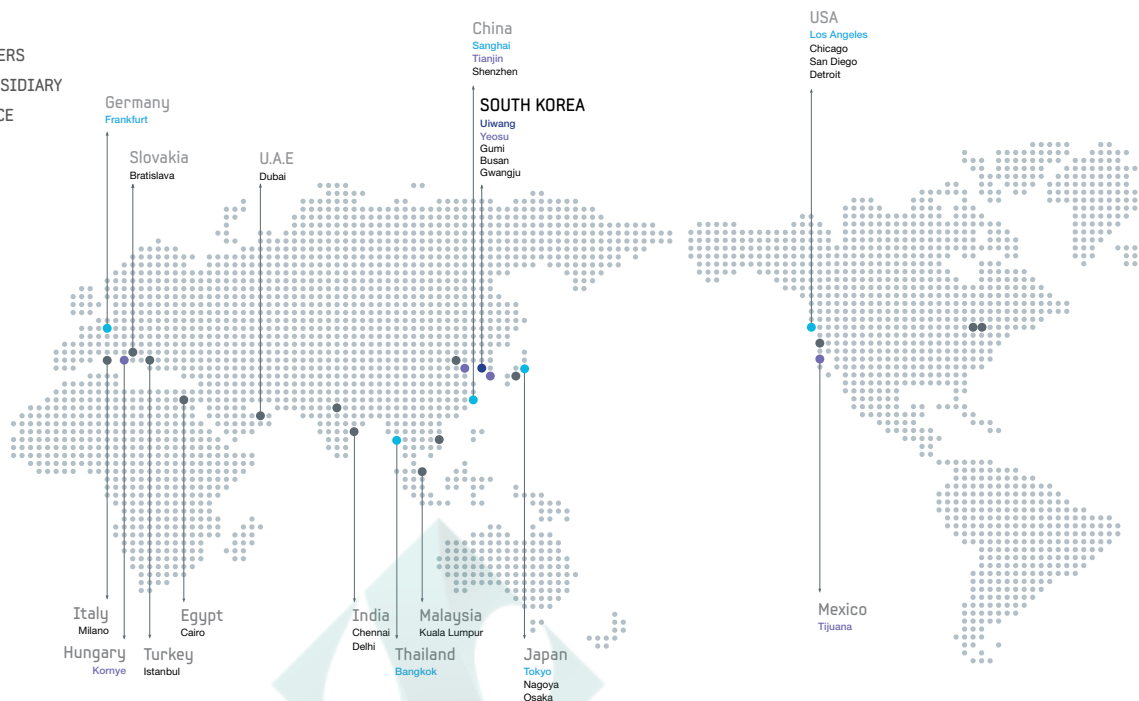

HEADQUARTERS

Samsung Cheil Industries Inc.
 332-2 Gocheon-dong Ulsang-si
 Gyeonggi-do, 437-711, Korea
 Tel: +82-31-596-3408
 Fax: +82-31-596-3490
 E-mail: chemical@samsung.com

GLOBAL SUBSIDIARY

Los Angeles, USA
Samsung Chemical Inc.
 Tel: +1-562-229-1307
 E-mail: james.ham@samsung.com

Frankfurt, Germany
Samsung Chemical Europe GmbH
 Tel: +49-6196-66-7490
 E-mail: jason.chung@samsung.com

Shanghai, China
Samsung Chemical Material Trading (Shanghai) Co., Ltd.
 Tel: +86-21-6270-3000(325)
 E-mail: yingshun.lee@samsung.com

Bangkok, Thailand
Samsung Chemical Thailand
 Tel: +66-2-624-6715
 E-mail: atcharaporn.p@samsung.com

Tokyo, Japan
Samsung Chemical Inc.
 Tel: +81-3-6234-2197
 E-mail: c77.song@samsung.com

SALES / SERVICE OFFICE

Asia
Shenzhen, China
 Tel: +86-755-8203-2323
 E-mail: evone.chen@samsung.com

Tianjin, China
 Tel: +86-22-2836-4261
 E-mail: zhengdao.lee@samsung.com

Nagoya, Japan
 Tel: +81-52-569-1807
 E-mail: boin56.noh@samsung.com

Osaka, Japan
 Tel: +81-6-6949-3162
 E-mail: f.naoki@samsung.com

Kuala Lumpur, Malaysia
 Tel: +60-3-2174-4534, 4570
 E-mail: jeffrey.kang@samsung.com

Chennai, India
 Tel: +91-98401-04251
 E-mail: deepak.lee@samsung.com

Delhi, India
 Tel: +91-81302-19193
 E-mail: yogendra.kang@samsung.com

Dubai, U.A.E
 Tel: +971-4-447-3411
 E-mail: moon357@samsung.com

Europe
Bratislava, Slovakia
 Tel: +421-90-170-2001
 E-mail: jh2407.kim@samsung.com

Istanbul, Turkey
 Tel: +90-541-231-0314
 E-mail: ferhat.gungor@samsung.com

Milano, Italy
 Tel: +39-2-83111840
 E-mail: yk.k@samsung.com

America

Chicago, U.S.A.
 Tel: +1-847-407-2845
 E-mail: jerry.tennant@samsung.com

San Diego, U.S.A.
 Tel: +1-619-278-0961
 E-mail: jongho82.yang@samsung.com

Detroit, U.S.A.
 Tel: +1-248-276-8484
 E-mail: brian.grosser@samsung.com

PLANT

Yeosu, Republic of Korea
 Tel: +82-61-689-1221
 E-mail: heuicheol.lee@samsung.com

Tianjin, China
 Tel: +86-22-5868-0291
 E-mail: mc007.jeon@samsung.com

Kornye, Hungary
 Tel: +36-34-814-120
 E-mail: bt.hyun@samsung.com

Tijuana, Mexico
 Tel: +52-664-627-4947
 E-mail: psy13560@samsung.com



STAVIAN[®]
CHEMICAL





Value⁺ your imagination

We provide value to turn your imagination into reality with our innovative materials and optimal solutions.

STAVIAN[®]
CHEMICAL

Note The information contained herein is provided by Samsung Cheil Industries, Inc. and its subsidiaries and affiliates (collectively referred to as "SAMSUNG") for information purposes only and should be used by individuals with technical experience and knowledge in the area. Samsung Cheil Industries does not make any representation or warranties of the usefulness or expected result of the information, and does not assume any responsibility whatsoever related to the use of the information. SCI-M-042013



CHEIL INDUSTRIES

starex®

www.samsungchemical.com

STAVIAN®
CHEMICAL